

AC/DC CLAMP-ON MILLIAMMETER

MODEL 700

INSTRUCTION MANUAL

Thank you very much for selecting our model 700 AC/DC Leakage Clamp Tester.

Before use the instrument, read this instruction manual completely and familiarize yourself thoroughly with all functions.

Keep this instruction manual carefully to take out whenever you need.

MULTI MEASURING INSTRUMENTS CO.,LTD.
Akihabara Murai Bldg., 7F, 1-26 Kanda Sakuma-cho,
Chiyoda-ku, Tokyo, 101-0025 Japan
TEL : 81-3-3251-7013 FAX : 81-3-3253-4278
Home Page : <http://www.multimic.com/>
E-mail : multi@multimic.com

- To use this instrument safely, read this "SAFETY SUMMARY" carefully and apply the instrument correctly.
- The CAUTIONs and WARNINGs which appear on the following pages are stated to prevent the operator & other people from the dangers and their properties from the damages beforehand.

△ WARNING : This symbol indicates the contents "Possibilities of the death or the serious wound can be supposed" caused from mis-operations.

△ CAUTION : This symbol indicates the contents "Possibilities of the injury or only the material damage can be supposed" caused from mis-operations.

○ OPERATION ENVIRONMENT

△ CAUTION

- Do not use or storage this instrument under the condition of direct rays of the sun, high temperature & humidity and or condensation, as it may cause the deformation and or the isolation defect of the instrument.
- Do not use this instrument in the environment influenced by acids, alkalis, organic solutions. corrosive gas, etc.
- Do not use or storage this instrument where the mechanical vibration can be directly transmitted, as it may cause defect of the instrument.
- Do not use this instrument nearby the appliances which generate strong magnetic field and or electric field, as it may cause mis-movement of the instrument.
- This instrument does not have the water / dust-proof structure. Do not use this instrument in the environment with a lot of dust and drops of water, as it may cause defect of the instrument.

○ OPERATION CONDITION & CONNECTION

△ WARNING

POSSIBLE ELECTRICAL SHOCK

- This instrument is for the use of low voltage circuit.
Do not make measurements of power lines carrying more than AC 600V.
Before use, check and confirm the voltage of circuit to be measured.
- Apply only the coated cables and do not clamp bare cables.

POSSIBLE ELECTRICAL SHOCK OR ACCIDENT

- Do not handle the instrument in the rain, at humid place, with a drop of water and or with wet hands.
- Do not use the instrument if the CT or CT case are damaged and if something is wrong with the CT cables.
- If excessive current is applied to the CT, the instrument will be heated and damaged. Use the CT according to the rating current.
- Do not apply the voltage more than AC 10V to the input and output terminals.

△ CAUTION

◆ FOR SAFETY USE

- Do not drop the instrument body and CT and or do not give the strong shock.
Do not put the heavy object on to the cable of CT and do not reconstruct.
- Be careful sufficiently not to drop or give shock to CT, as it may cause damage to the fitting part of Ct and it will cause wrong influence to the measurement.
- Be careful not to bend or pull the base of CT cable, in order to avoid the troubles
by disconnection.
- Do not disassemble the instrument.

1. GENERAL

- This instrument can measure DC current (1mA~1000mA) & AC current (1mA~10A) without cutting off the power lines and has detachable current sensor.
- In case of measurement for DC current, the ordinary clamp tester cannot measure lower range current accurately due to the influences of magnetization and terrestrial magnetism. This instrument is a epoch-making clamp tester which can measure low range DC current very accurately by using high sensitive materials & exciting magnetization method to CT.

2. CAUTION BEFORE USE

After opening the package, check the appearance of instrument and confirm if there is no lack of accessories. If any damage and or any lack has been found, contact the dealer you bought this instrument.

< COMPOSITION OF MODEL 700 >

- Instrument Body (LR6 Battery x4 installed) 1
- CT Sensor (CTP-05DC) 1
- Carrying Case 1
- Instruction Manual 1

3. SPECIFICATIONS

(1) INSTRUMENT SPECIFICATION

Measuring function	: AC/DC current
Measuring method	: Clamp CT (Slide/Hook Type)
Measuring ranges	: DC 100mA/1000mA, AC 100mA/1000mA/10A (45Hz~65Hz)
AC current detection	: Average sensing
A/D conversion	: Dual integration method
Display	: Max. 2000 count on LCD with annunciator
Over range indication	: "OL" mark on LCD
Data hold indication	: "DH" mark on LCD
Zero adjustment	: For DC current range, by "0 ADJ" switch
Sampling rate	: 6 times/sec. (AC) and 1 time/sec. (DC)
Low battery indication	: "B" mark on LCD
Signal Output	: DC 100mV full scale to each range, converted to analog signal which becomes zero in case of reaching more than 110% of the range to show over range. (output impedance : less than 10KΩ)
Auto power off	: Approx. 10 minutes after power on with "APO" sign on LCD.
Dissolution of Auto off	: Dissolve Auto power off function by "NOT AUTO" switch.

(2) CURRENT SENSOR SPECIFICATION

Jaw opening capability : 5mm Φ (CTP-05DC), Split-Core Type
 Withstanding voltage : AC 3700V, 1 minute between metal core and grip
 Cable length : 1.2m
 Safety Standard : IEC61010-2-032, CAT II 600V or CAT III 300V
 Dimension & Weight : 19(W)x113(H)x28(D)mm, approx. 100g

(3) GENERAL SPECIFICATION

Power Supply : Alkaline Battery (LR6) x 4 pcs.
 Consumption Current : Approx. 9mA (Approx. 200h for continuous use)
 Operating Circuit Voltage : Low voltage circuit, less than AC/DC 600V
 Operating Temperature : 0~50°C, < 85%RH (without condensation)
 Storage Temperature : -10~60°C, < 70%RH (without condensation)
 Withstanding Voltage : AC 3700V/1 minute between CT core and grip
 Insulation Resistance : 100MΩ by DC500V insulation tester between CT core and grip
 Safety Standard : IEC61010-1/61010-2-032, CAT II 600V or CAT III 300V
 Dimension & Weight : 78(W)x155(H)x32(D)mm, approx. 280g
 Accessories : Battery (LR6) (Internally installed)..... 4
 Carrying Case 1
 CT (CTP-05DC)..... 1
 Insulation Manual 1

(4) Accuracy (23°C ± 5°C, less than 85%RH)

DC Current (After zero adjustment by “0 ADJ” switch)

Range	Measuring Range	Resolution	Accuracy
100mA	0.1~±50.00mA	0.01mA	±1%rdg±5dgt
	±50.01~±99.99mA		±1%rdg±10dgt
1000mA	1~±300mA	0.1mA	±1%rdg±10dgt
	±300~±700mA		±2%rdg±10dgt
	±700~±999.9mA		±3%rdg±10dgt

- ※ Influence of Terrestrial Magnetism : Less than ±0.5mA
- ※ Influence of Magnetization : Less than ±0.5mA by DC 1.5A on/off
- ※ Influence of CT Open/Close : Less than ±0.7mA
- ※ Max Input Current : DC 1.5A (In case of overinput more than DC 1.5A, output of CT will be lowered and the display will not become “OL”).

AC Current

Range	Measuring Range	Resolution	Accuracy
100mA	0~99.99mA	0.01mA	±1%rdg±10dgt(50/60Hz)
1000mA	0~999.9mA	0.1mA	±1%rdg±10dgt(50/60Hz)
10A	0~9.999A	0.001mA	±1%rdg±10dgt(50/60Hz)

- ※ Max Input Current : AC 20A

4. NAME OF PART & EXPLANATION

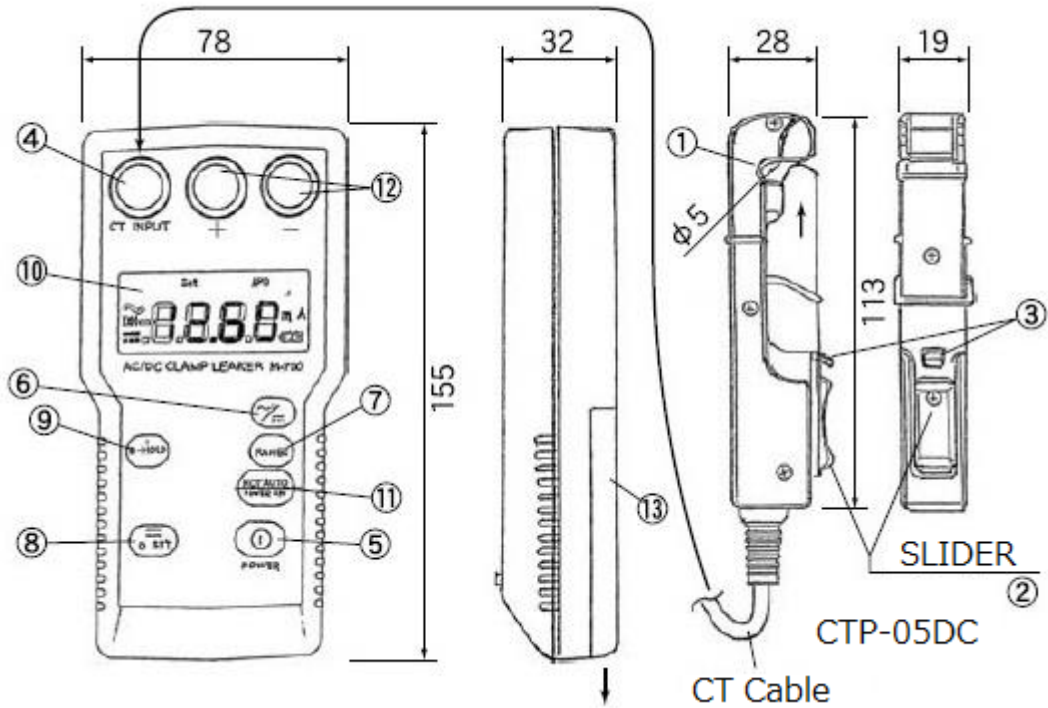

- ① Clamp CT (Slide/Hook Type) : Current sensor for detecting AC/DC current.
- ② Grip of CT : Can open/close CT by up & down slider
- ③ Operation Lever : When closing CT completely, the lever becomes up and locked. For opening CT, make the lever down and move the slider.
- ④ CT Input Connector : Output signal from CT is input to this terminal.
- ⑤ Power Switch (POWER) : By push one time, power will be "on" and by push again, power will be "off".
- ⑥ AC/DC Select Switch : By push of power switch, the range is for DC current and by push one time, the range will become AC current.
- ⑦ Range Switch (RANGE) : For selection of AC&DC current measuring range
- ⑧ Zero Adjustment Switch (0 SET) : The switch to make display "0" for DC current measurement. Before operation, put CT close the conductor to be measured and push this switch, then clamp CT to the conductor to measure the current.
- ⑨ Data Hold Switch (D-HOLD): By push one time, "DH" sign will be on LCD and by push once more, this function will be released.
- ⑩ LCD Display : Display of the measured values, measuring mode, condition and battery activity.

- ⑪ Auto Power Off Release Switch : For long hours measurement, push this switch to release auto power off function.
In this case, "APO" sign on LCD will be disappeared.
- ⑫ Output Signal for Recorder (REC OUT) : In case of measuring current for long hours, connect this signal with recorder. The output signal is DC 100mV full scale for each range.
In case of overrange, the signal becomes "0".
- ⑬ Battery Cover (Rear Side) : Remove this cover to change the batteries.

5. OPEARTION PROCEDURE

(5-1) Change of Batteries

Confirm that the power is "OFF".
Take out the instrument from carrying case and remove the screw of battery cover by ⊕ driver. Slide the battery cover to the arrow direction and remove the battery cover. Take out 4 batteries and replace them. Put the battery cover back to the original position and tighten the screw.

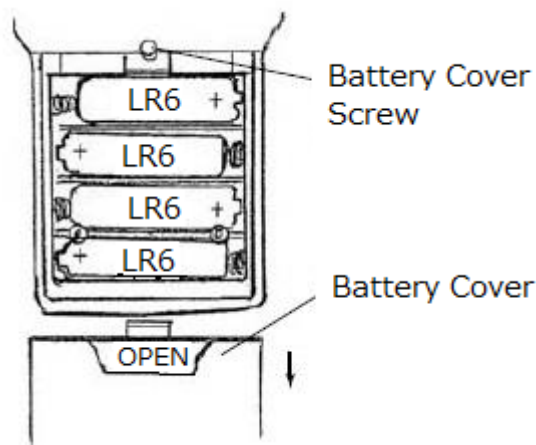

- 「B」 sign will appear on the display when batteries are exhausted and get less than operation voltage. Replace to new batteries immediately.
- Do not use the batteries mixed new one and once used and or different kind ones.

△ WARNING

POSSIBLE ELECTRICAL SHOCK

- When removed the battery cover, put it back to the original position certainly.
Do not operate the instrument, leaving the battery cover off.
- Do not replace the batteries with clamping CT to the conductor.

△ CAUTION

POSSIBLE DAMAGE TO THE INSTRUMENT

- When not using the instrument for a long period, remove the batteries and keep separately. The batteries may leak and may cause damage to the instrument.

(5-2) Measurement

To use the instrument safely, follow the contents described in WARNING and CAUTION without fail.

△ WARNING

POSSIBLE ELECTRICAL SHOCK

- For safety, use the instrument in circuit less than 500V.
Before operation, confirm the circuit voltage to be used.

POSSIBLE ELECTRICAL SHOCK OR ACCIDENT

- Do not handle the instrument in the rain, at humid place, with a drop of water and or with wet hands.
- Do not use the instrument if the CT or CT case are damaged.
- Do not use the instrument, leaving the battery cover off.

POSSIBLE FIRE HAZARD AND BURN ACCIDENT

- Part of ZCT will get heat when applying excessive current.
Do not apply more than maximum capable current (20A rms) to ZCT part.

(5-2-1) DC Current Measurement

- ① Insert the connector of CTP-05DC to "CT INPUT" of the instrument body.
- ② Set the "POWER" switch to "ON".
(Initially, == 100mA range will be displayed)
- ③ Select the range according to the current value to be measured (by Range Switch).
- ④ Put the CT nearby the conductor to be measured with closing CT completely and push "0 SET" switch to make display value "0".
("0" point may be unsteady by influences of terrestrial magnetism and outer magnetic field but it is not out of order).
- ⑤ Open the CT and clamp it to the conductor to be measured, setting current and CT directions to become the same.
Close the CT completely. (When CT was closed completely, the lever will be locked automatically.
To open CT again, pull down the lever below and slide down it).
- ⑥ Read the displayed value. (In case of over range, "OL" will be displayed).

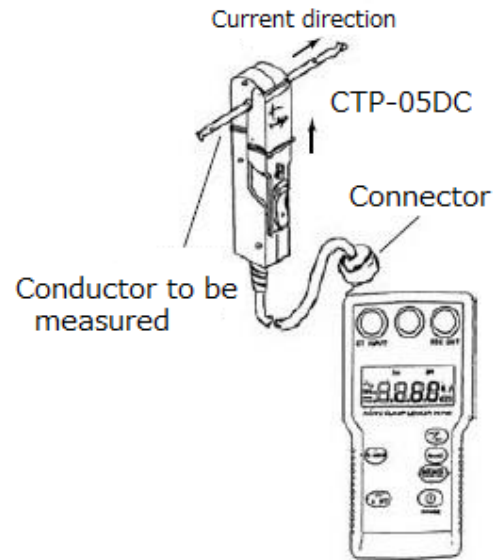

Note : For leakage current measurement in DC current circuit, clamp the CT to 2 wires en bloc.

△ CAUTION

1. For DC current measurement, put the CT (CTP-05DC) nearby the conductor to be measured, with closing CT completely. In this condition, make "0" set and clamp the CT to the conductor to be measured and close the CT completely (lever locked) and then, read the measured value.
2. Do not "0" set with opening CT. It may cause the error.
3. Do not apply DC current more than 1.5A. It may cause the measurement error and or defect.

△ CAUTION

- Do not use the instrument where the mechanical vibration is directly transmitted. It may cause the error.
- Do not measure with CT close to magnet, object generates strong magnetic field and or magnetized object. It may cause the error.

(5-2-2) AC Current Measurement

- ① Insert the connector of CTP-05DC to “CT INPUT” of the instrument body.
- ② Set the “POWER” switch to “ON”. (Initially, = 100mA range will be displayed)
- ③ Push AC/DC Select Switch (Display will become ~100mA range).
- ④ Select the range according to the current value to be measured (by Range Switch).
- ⑤ Open the CT and clamp it to the conductor to be measured.
Close the CT completely.
- ⑥ Read the displayed value (In case of over range, “OL” will be displayed).
Push Data Hold Switch to hold the measured value.

<Measurement of Leakage Current>

- ① Leakage Current Measurement for Grounding Line
Make measurement in the same manner as AC Current Measurement.
 - ② Leakage Current Measurement except for Grounding Line
The operation is the same as AC Current Measurement but clamp the CT to 2 wires (1P/2W) and or to 3 wires (3P/3W) en bloc.
- ※ This instruments has auto power-off function and the power will become off approx. 10 minutes after the final switch operation.

(5-2-3) Measurement with Use of Output Signal for Recorder

In case of monitoring current for long hours, use the output signal for recorder.

- ① Connect with the recorder as per the drawing.
- ② Connect the CT to “CT INPUT” of the instrument body.
- ③ Set the “POWER” Switch to “ON”.
- ④ Push Auto Power Off Dissolving Switch (NOT AUTO) to take off this function. (“APO” sign will be disappeared on LCD).
- ⑤ Set the power on of the recorder.
- ⑥ Make the setting to be measured.
- ⑦ Clamp CT to the conductor to be measured.
- ⑧ Confirm the most appropriate measuring range and start record.

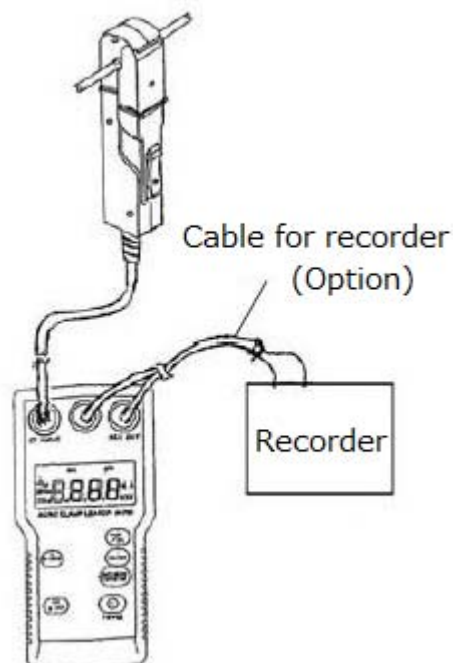

△ CAUTION

1. In case of changing the measuring range of DC current measurement, once remove the CT from the conductor and make “0” adjustment and then, clamp the CT to the conductor to be measured again.
(In details, please refer to DC Current Measurement).
2. The output signal for recorder is DC 100mV to full scale of each range.
In case of over range, the output signal will become 0mV compulsorily at more than 110% of the range to show this condition.
3. Dissolve the auto power-off function in case of measurement by using output signal for recorder.

6. REPAIR SERVICE

When requesting for repair service, Please bring the instrument directly to the dealer where you bought.

When mailing the instrument, always pack it in its original or equivalent packing materials to avoid any damage during the transportation and also put together with documents showing your name, address, phone number and defect point.

7. WARRANTY

This instrument is sent out from our factory after the sufficient internal inspections but if you find any defect due to the fault in our workmanship or the original parts, please contact the dealer where you bought the instrument.

The warranty period is 12 months from the date of purchase and the instrument shall be repaired at free of charge, provided that we judge the cause of defect is obviously resulted from our responsibility.

GURANTEE REGULATIONS

1. This instrument is warranted for the operation under normal use for 12 months from the date of purchase.
2. This warranty does not cover the following defects:
 - a. Defect caused from the improper use and operation.
 - b. Defect caused from the use, operation and storage beyond the original specifications, designs and conditions.
 - c. Defect caused from the renovations or repairs done by someone else than us or our representatives.
 - d. Defect not caused from our responsibilities.

APPENDIX

HOW TO OPEN/CLOSE CTP-05DC CT SENSOR

(1) Open

To open CT of CTP-05DC,
make ③ OPERATION LEVER below.
The lock will be released and CT will
be opened by sliding down ② SLIDER
with putting the finger onto the lever.

(2) Close

To close CT of CTP-05DC,
put the finger onto the bottom of ③
SLIDER and slide it up to the place
where the slider becomes tight.

Then, push up ③ OPERATION LEVER
slowly to make CT locked completely.

NOTE : The displayed value will become
unstable, if CT is not closed completely.