

# AC CURRENT MINI DIGITAL CLAMP TESTER

MODEL 210

## INSTRUCTION MANUAL

Thank you very much for selecting our digital AC current clamp-on tester.

This model is complex instrument and employ a very reliable mechanical/electronic design.

Before you use your new instrument, read this Instruction Manual completely and familiarize yourself thoroughly with all functions. With proper use and care, your tester will give you years of satisfactory service.

### 1. FEATURES

- Wide range of current measurements from AC 0.01A to 200A with 33mm  $\phi$  CT.
- Data hold function. Especially useful when working in dark or hard to get areas.
- Ultra compact size and high accurate AC clamp-on tester.

### 2. SPECIFICATION

Measuring method	Dual integration mode
Display	3.5 digit LCD
Range	AC 20A/200A
Ranging	Manual ranging

Accuracy: AC 50/60Hz (23°C ± 5°C, less than 80% RH)

Range	Mini. Resolution	Accuracy
AC 20A	0.01A	± 1.2%rdg ± 5dgt
AC 200A	0.1A	

Jaw opening capability	23mm $\phi$
Over range indication	Blanking of all digits except MSD1
Maximum indication	1999 count
Low battery indication	"B" mark on LCD readout
Data hold indication	"D·H" mark on LCD readout
Sampling time	2 times/sec.
Limitation of circuit voltage	Less than AC 600V
Withstanding voltage	AC3700V/1 minute between CT core and outer case
Insulation resistance	10M $\Omega$ or more between internal circuit and CT core.
Operating temperature	0°C to +40°C, < 80%RH (non-condensing)
Storage temperature	-10°C to +60°C, < 70% RH (non-condensing)
Power supply	LR-44(1.5V)x2 or SR-44x2
Power consumption	Approx. 2.5mW
Battery life	Approx. 100 hours (LR-44) Approx. 200 hours (SR-44)
Size	48(W)x146(H)x20(D)mm
Weight	Approx. 80g
Accessories	Batteries (LR-44).....2 Instruction manual.....1 Soft case.....1

### 3. CAUTION

- Before operating this instrument, familiarize yourself with all instructions outlined in this manual.
- Always check to make sure that the function switch is set to the proper position.
- When making measurements, use CAUTION as dangerous voltages may be present in normally safe areas.
- To avoid electrical shock, use CAUTION when working above 60V DC or 25V AC rms. Such voltages pose a shock hazard.
- Never make measurements with the battery cover OFF.
- Never fail to keep the maximum tolerable input.
- Never operate this instrument if it becomes wet, damp or has any liquid condensation build-up on any part of the instrument.
- Never make measurements for uninsulated conductors or bus bars.

## 4. DIMENSIONS AND PANEL FUNCTION

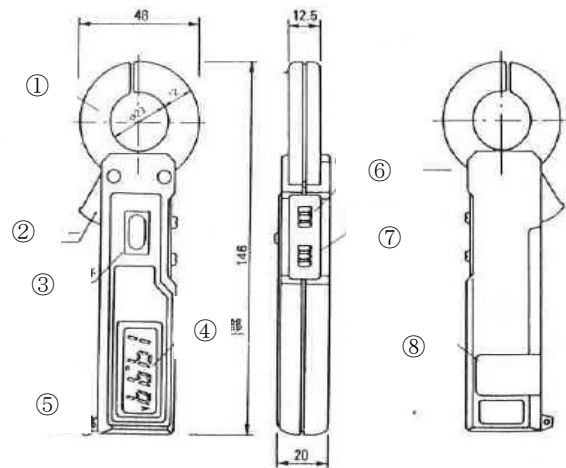

- ① Current transducer (Jaw)
- ② Jaw opening lever
- ③ Data hold switch
- ④ LCD display

- ⑤ Hand strap
- ⑥ Range switch
- ⑦ Power switch
- ⑧ Battery cover

## 5. METHOD OF MEASUREMENT

### 5-1 Preparation and Caution before Measurement

- Before making measurement, install the batteries. (Two LR-44 or SR-44)
- Avoid using the tester in places subject to high temperature, humidity or excessive vibration.
- Do not use or store the tester in an area subject to magnetic fields or electric noises. Unstable reading and measurement error may result.
- Before measurement, be sure the data hold switch is set to "OFF".  
It is impossible to make measurement if the data hold switch is set to "ON".
- Remove the batteries, if the tester will not be used for a long period.

### 5-2 AC Current Measurement

- ① Set the power switch to "ON" position.
- ② Set the range selector switch to appropriate range to the current to be measured.
- ③ Clamp the conductor of the circuit under test with current transducer.  
Note: Clamp around only one conductor in the circuit to be measured.
- ④ Read the displayed value.
- ⑤ If you make measurement in a dark place or in a place where it is difficult to see the readings, use the data hold switch.
- ⑥ After measurement, set the power switch to "OFF".

#### CAUTION:

This tester is designed for low voltage applications.  
To avoid electrical shock or damage, the measurement is limited to the circuit under 600V AC.

## 6. REPLACEMENT OF BATTERIES

When the battery becomes exhausted or drops below the operating voltage, the "B" mark is displayed. Turn the power switch to "OFF", prior to installing batteries. To install the batteries, remove the battery cover located on the unit back.

(See Fig.2)

Insert the two LR-44 or SR-44 into the battery case making sure that proper polarity is observed. (See Fig.3)

Always replace both batteries at the same time. If the difference between the voltages of the batteries is big, the measurement error may be caused.

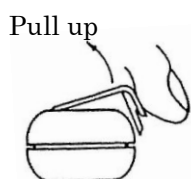

Fig.2

Place batteries with positive side up

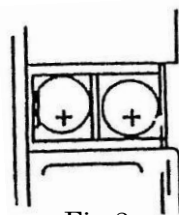

Fig.3

## REPAIR SERVICE

When requesting for repair service, please bring the instrument directly to the dealer where you bought.

When mailing the instrument, always pack it in its original or equivalent packing materials to avoid any damage during the transportation and also put together with documents showing your name, address, phone number and defect point.

## WARRANTY

This instrument is sent out from our factory after the sufficient internal inspections but if you find any defect due to the fault in our workmanship or the original parts, please contact the dealer where you bought the instrument.

The warranty period is 12 months from the date of purchase and the instrument shall be repaired at free of charge, provided that we judge the cause of defect is obviously resulted from our responsibility.

## MULTI MEASURING INSTRUMENTS CO.,LTD.

Akihabara Murai Bldg., 7F, 1-26 Kanda Sakuma-cho,

Chiyoda-ku, Tokyo,101-0025 Japan

TEL : 81-3-3251-7016 FAX : 81-3-3253-4278

Home Page : <http://www.multimic.com/>

E-mail : multi@multimic.com